



Turbo Clean intelligent
oil-fired boiler

MISSION™ OS-TCi

The oil-fired MISSION™ OS-TCi is supplied as a pre-assembled boiler unit with a user-friendly, integrated pressure atomizing burner controlled and monitored with a MISSION™ Control Touch system.

The reliable, high efficiency boiler is designed to be self-cleaning to the highest possible degree. Maintenance is easy and environmentally friendly.

Capacity range: 1,200–8,000 kg/h



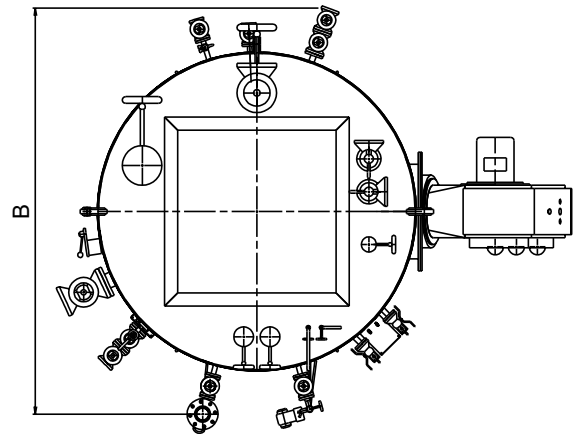
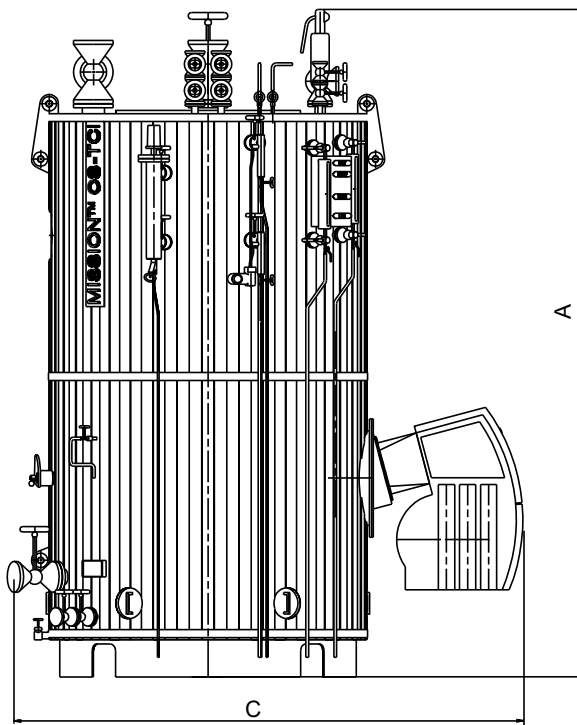

MISSION™ OS-TCi boiler - Capacity & dimensions

Steam capacity	Design pressure	Dimensions			Boiler operational weight
		A	B	C	
kg/h	bar (g)	mm	mm	mm	ton
1,200	10	3,875	1,370	2,590	4.7
1,600	10	4,025	1,470	2,720	5.5
2,000	10	4,115	1,570	2,810	6.3
2,500	10	4,235	1,670	3,020	7.3
3,500	10	4,480	1,820	3,170	8.9
4,500	10	4,675	1,970	3,310	10.5
5,500	10	4,855	2,070	3,580	12.0
6,500	10	4,875	2,270	3,770	14.5
8,000	10	5,065	2,420	3,910	16.8

Max. operating pressure: 8 bar (g)

DATA SHEET series

© Aalborg Industries (Design data are subject to change without prior notice).